

4

3

2

1

METER SOFTENER

MODEL NO. NCSMF-WS3-450-C3948

CAPACITY:

MIN. 360,000 grs. @ 10 lbs. / cu. ft.
MAX. 450,000 grs. @ 15 lbs. / cu. ft.

FLOW RATE:

NORMAL 144 gpm.
PEAK 186 gpm
BACKWASH 25 gpm.

TANK SIZE: 24" x 72"

COMPOSITE

MEDIA:

RESIN 15 cu.ft.
GRAVEL 350 lbs.

PIPE SIZE: PVC

INLET: 3"
OUTLET: 3"
VALVE: 3"
DRAIN: 1-1/2"
BRINE: 1"
METER: 3"

BRINE TANK

MODEL NUMBER: BT3948R-494-5

TANK SIZE: 39" x 48"

POLYETHYLENE

CAPACITY

250 gals.
2,200 lbs./salt

BRINE VALVE: 494

BRINE WELL: 5"

WEIGHT (APPROX)

TOTAL SHIPPING: 1,520 lbs.

TOTAL SPACE REQUIRED (APPROX)

73"L x 39"W x 103"H

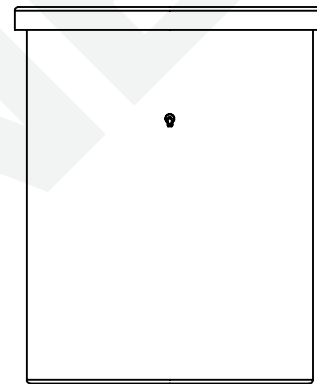

39" x 48"
BRINE TANK

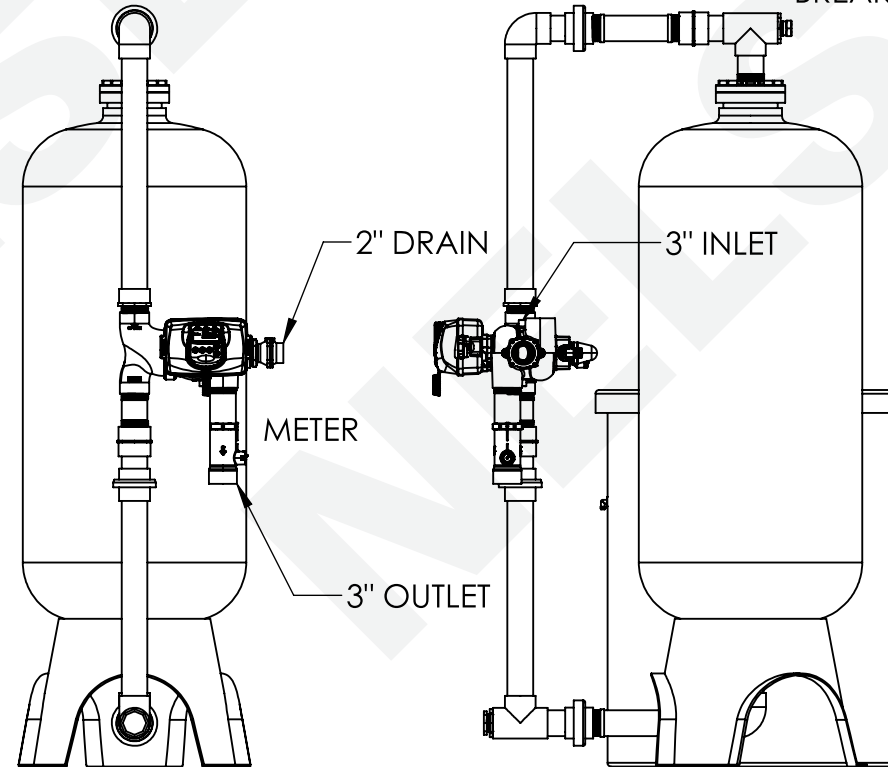

30" x 72"
SOFTENER

(SIDE VIEW)



VACUUM
BREAKER



NOTE:
PEAK FLOWS ARE NOT RECOMENDED FOR EXTENDED PERIODS OF TIME.
ALL DASHED PIPE, VALVES, AND FITTINGS NOT PROVIDED BY NELSEN CORPORATION

NELSEN
CORPORATION

NELSEN CORPORATION
OHIO • ARIZONA • TEXAS • FLORIDA
3250 BARBER RD - NORTON, OH 44203
800-362-9686
NelsenWaterSolutions.com

DO NOT SCALE DRAWING

UNLESS OTHERWISE SPECIFIED:
DIMENSIONS ARE IN INCHES
PART DIMENSIONS ARE +/- 1/32"
ASSEMBLY DIMENSIONS ARE
APPROXIMATE

PROPRIETARY AND CONFIDENTIAL
THE INFORMATION CONTAINED IN
THIS DRAWING IS THE SOLE PROPERTY
OF NELSEN CORPORATION INC. ANY
REPRODUCTION IN PART OR AS A
WHOLE WITHOUT THE WRITTEN
PERMISSION OF NELSEN CORP. IS
PROHIBITED.

TITLE: GENERAL ARRANGEMENT DRAWING
SOFTENER 450K FIBERGLASS TANK
SIMPLEX METER SYSTEM

	NAME	DATE	DWG. NO.
DRAWN	RAR	05-31-17	NCSMF-WS3-450-C3948
CHECKED			
ENGR APPR.			
SIZE B			SCALE: 1:32
			SHEET 1 OF 1

4

3

2

1

B

B

A

A