

# DUPLEX NXT SOFTENER

MODEL NO. 29/17NXT-DUP-150-C2450

CAPACITY: (each tank)

MIN. 120,000 grs. @ 10 lbs./cu.ft.

MAX. 150,000 grs. @ 15 lbs./cu.ft.

FLOW RATE: (each tank)

NORMAL 50 gpm.

PEAK 62 gpm.

BACKWASH 10 gpm

TANK SIZE: 18" x 65"

COMPOSITE

MEDIA: (each tank)

RESIN 5 cu.ft.

GRAVEL 100 lbs.

PIPE SIZE:

INLET 2"

OUTLET 2"

DRAIN 1"

BRINE 1/2"

METER 2"

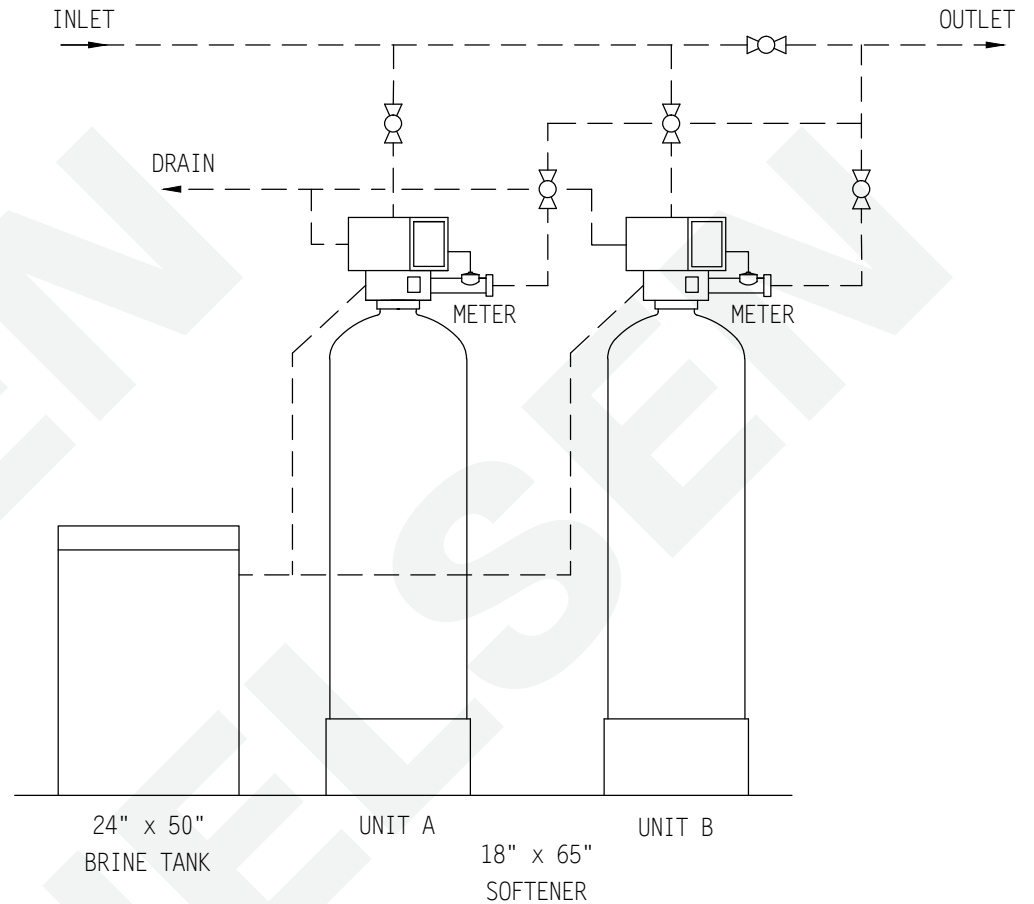

## BRINE TANK

MODEL NO. BT2450R-454HF-5

TANK SIZE: 24" x 50"

POLYETHYLENE

CAPACITY:

100 gals.

900 lbs./salt

BRINE VALVE: 454HF

BRINE WELL: 5"

WEIGHT (APPROX)

TOTAL SHIPPING 1,130 lbs.

## NOTE:

ALL DASHED PIPE, VALVES, AND FITTINGS NOT PROVIDED BY NELSEN CORPORATION.

SPACE REQUIRED (APPROX)

68"L x 24"W x 79"H

PEAK FLOWS ARE NOT RECOMMENDED FOR EXTENDED PERIODS OF TIME.

**DO NOT SCALE DRAWING**

THIS DRAWING IS ISSUED IN CONFIDENCE AND CANNOT BE REPRODUCED OR USED TO MANUFACTURE ANYTHING SHOWN OR REFERRED TO WITHOUT DIRECT WRITTEN PERMISSION FROM NELSEN CORPORATION.

**NELSEN**  
CORPORATION

**NELSEN CORPORATION**  
OHIO • ARIZONA • TEXAS • FLORIDA  
3250 BARBER RD - NORTON, OH 44203  
800-362-9686  
NELSENCORP.COM/COMMERCIAL

GENERAL ARRANGEMENT DWG.  
SOFTENER 150K  
DUPLEX NXT SYSTEM

DRAWN BY:	RAR
DATE:	03-03-17
CHECKED BY:	
PAGE 1 OF 1	REV:

DWG. NO.  
**29/17NXT-DUP-150-C2450**