

DUPLEX NXT SOFTENER

MODEL NO. 29/17NXT-DUP-210-C2450

CAPACITY: (each tank)

MIN. 168,000 grs. @ 10 lbs./cu.ft.

MAX. 210,000 grs. @ 15 lbs./cu.ft.

FLOW RATE: (each tank)

NORMAL 55 gpm.

PEAK 77 gpm.

BACKWASH 12 gpm.

TANK SIZE: 21" x 62"

COMPOSITE

MEDIA: (each tank)

RESIN 7 cu.ft.

GRAVEL 150 lbs.

PIPE SIZE:

INLET 2"

OUTLET 2"

DRAIN 1"

BRINE 1/2"

METER 2"

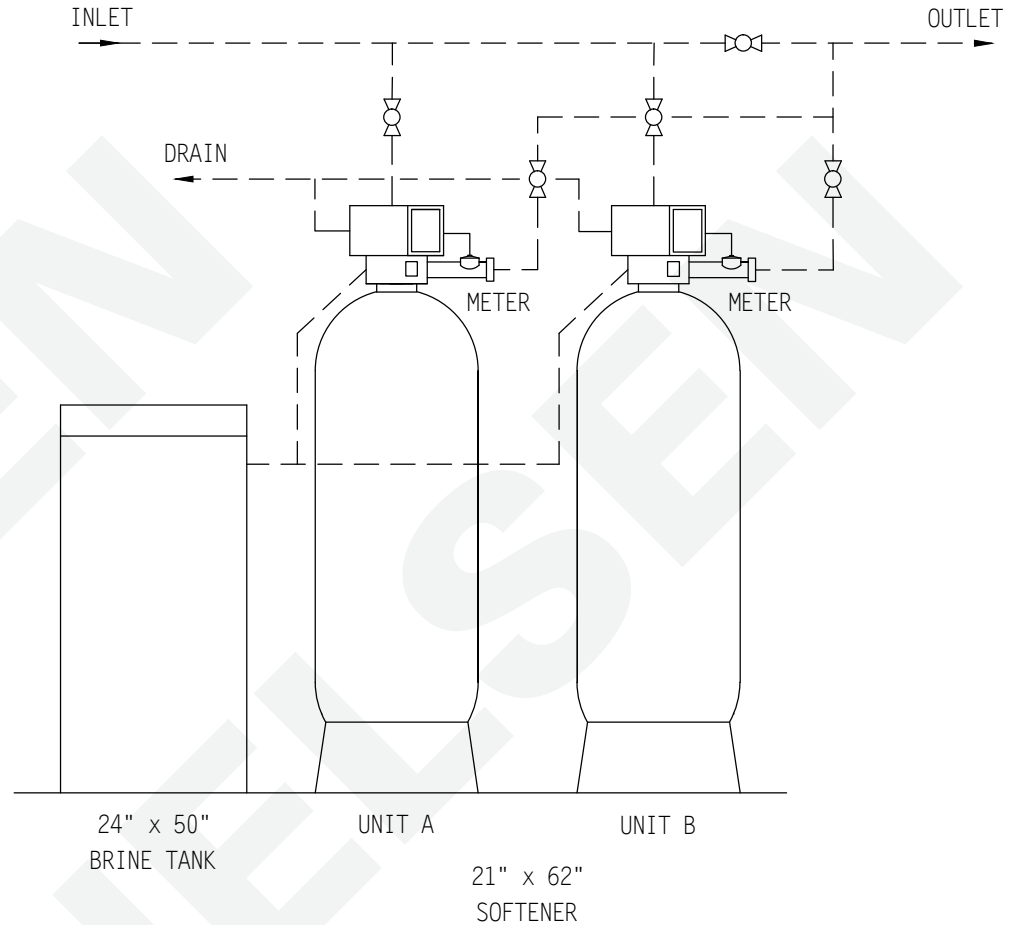

BRINE TANK

MODEL NO. BT2450R-454HF-5

TANK SIZE: 24" x 50"

POLYETHYLENE

CAPACITY:

100 gals.

900 lbs./salt

BRINE VALVE: 454HF

BRINE WELL: 5"

WEIGHT (APPROX)

TOTAL SHIPPING 1,460 lbs.

NOTE:

ALL DASHED PIPE, VALVES, AND FITTINGS NOT PROVIDED BY NELSEN CORPORATION.

SPACE REQUIRED (APPROX)

74"L x 24"W x 79"H

PEAK FLOWS ARE NOT RECOMMENDED FOR EXTENDED PERIODS OF TIME.

DO NOT SCALE DRAWING

THIS DRAWING IS ISSUED IN CONFIDENCE AND CANNOT BE REPRODUCED OR USED TO MANUFACTURE ANYTHING SHOWN OR REFERRED TO WITHOUT DIRECT WRITTEN PERMISSION FROM NELSEN CORPORATION.

NELSEN CORPORATION		NELSEN CORPORATION OHIO • ARIZONA • TEXAS • FLORIDA 3250 BARBER RD - NORTON, OH 44203 800-362-9686 NELSENCORP.COM/COMMERCIAL
GENERAL ARRANGEMENT DWG. SOFTENER 210K DUPLEX NXT SYSTEM		
DRAWN BY:	RAR	DWG. NO. 29/17NXT-DUP-210-C2450
DATE:	03-03-17	
CHECKED BY:		
PAGE 1 OF 1	REV:	