

DUPLEX NXT SOFTENER

MODEL NO. 29/17NXT-DUP-300-C3048

CAPACITY: (each tank)

MIN. 240,000 grs. @ 10 lbs./cu.ft.

MAX. 300,000 grs. @ 15 lbs./cu.ft.

FLOW RATE: (each tank)

NORMAL 60 gpm.

PEAK 95 gpm.

BACKWASH 15 gpm.

TANK SIZE: 24" x 72"

COMPOSITE

MEDIA: (each tank)

RESIN 10 cu.ft.

GRAVEL 250 lbs.

PIPE SIZE:

INLET 2"

OUTLET 2"

DRAIN 1"

BRINE 1/2"

METER 2"

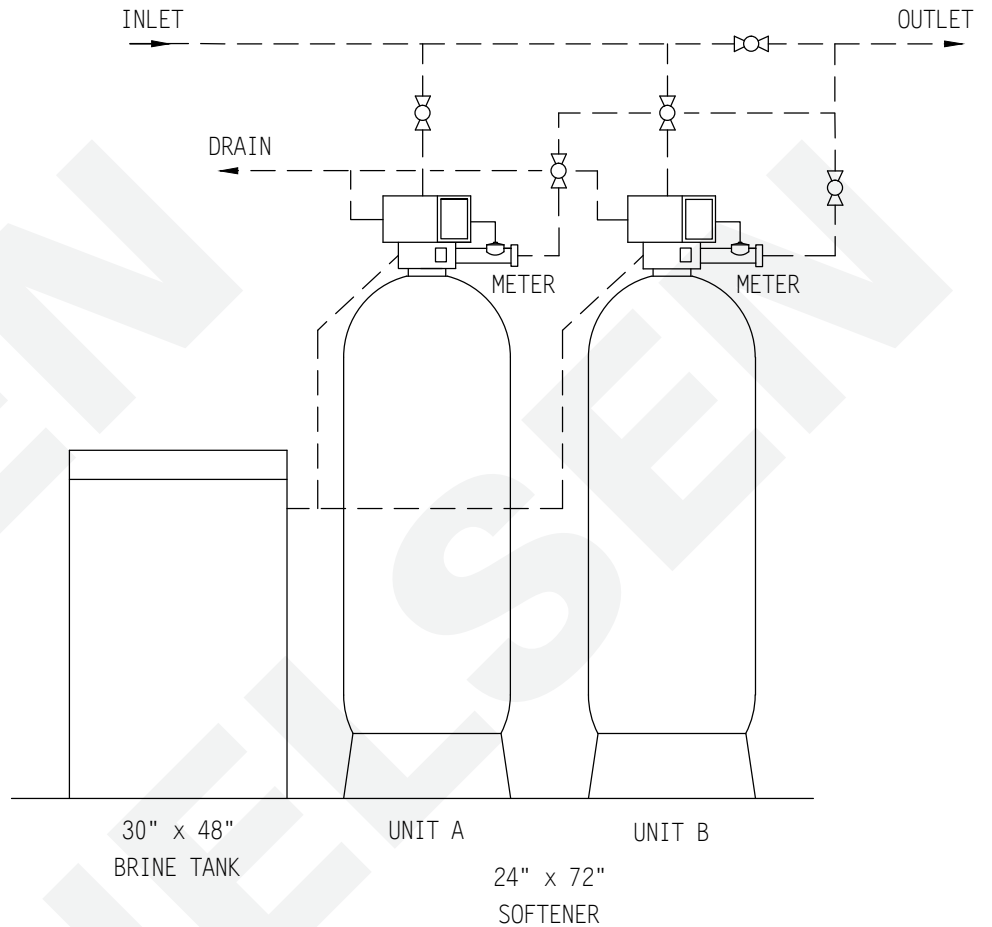

BRINE TANK

MODEL NO. BT3048R-454HF-5

TANK SIZE: 30" x 48"

POLYETHYLENE

CAPACITY:

145 gals.

1,200 lbs./salt

BRINE VALVE: 454HF

BRINE WELL: 5"

WEIGHT (APPROX)

TOTAL SHIPPING 2,210 lbs.

NOTE:

ALL DASHED PIPE, VALVES, AND FITTINGS NOT PROVIDED BY NELSEN CORPORATION.

SPACE REQUIRED (APPROX)

86"L x 30"W x 86"H

PEAK FLOWS ARE NOT RECOMMENDED FOR EXTENDED PERIODS OF TIME.

DO NOT SCALE DRAWING

THIS DRAWING IS ISSUED IN CONFIDENCE AND CANNOT BE REPRODUCED OR USED TO MANUFACTURE ANYTHING SHOWN OR REFERRED TO WITHOUT DIRECT WRITTEN PERMISSION FROM NELSEN CORPORATION.

		NELSEN CORPORATION OHIO • ARIZONA • TEXAS • FLORIDA 3250 BARBER RD - NORTON, OH 44203 800-362-9686 NELSENCORP.COM/COMMERCIAL	
		GENERAL ARRANGEMENT DWG. SOFTENER 300K DUPLEX NXT SYSTEM	
DRAWN BY: RAR DATE: 03-03-17 CHECKED BY: PAGE 1 OF 1	REV:	DWG. NO. 29/17NXT-DUP-300-C3048	