

# DUPLEX NXT SOFTENER

MODEL NO. 29/17NXT-DUP-450-C3948

CAPACITY: (each tank)

MIN. 360,000 grs. @ 10 lbs./cu.ft.

MAX. 450,000 grs. @ 15 lbs./cu.ft.

FLOW RATE: (each tank)

NORMAL 75 gpm.

PEAK 140 gpm.

BACKWASH 25 gpm.

TANK SIZE: 30" x 72"

COMPOSITE

MEDIA: (each tank)

RESIN 15 cu.ft.

GRAVEL 350 lbs.

PIPE SIZE:

INLET 2"

OUTLET 2"

DRAIN 1"

BRINE 1/2"

METER 2"

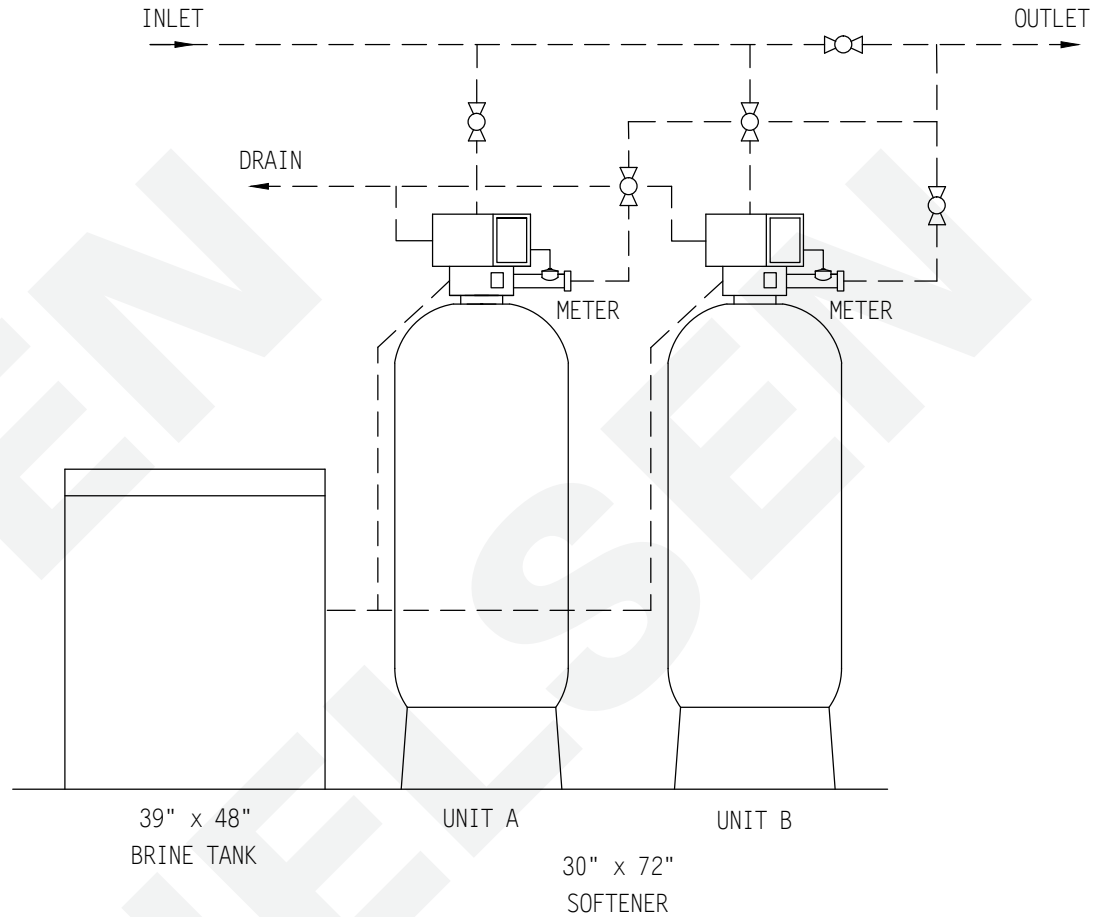

## BRINE TANK

MODEL NO. BT3948R-454HF-5

TANK SIZE: 39" x 48"

POLYETHYLENE

CAPACITY:

250 gals.

2,200 lbs./salt

BRINE VALVE: 454HF

BRINE WELL: 5"

WEIGHT (APPROX)

TOTAL SHIPPING 3,105 lbs.

## NOTE:

ALL DASHED PIPE, VALVES, AND FITTINGS NOT PROVIDED BY NELSEN CORPORATION.

SPACE REQUIRED (APPROX)

107"L x 39"W x 93"H

PEAK FLOWS ARE NOT RECOMMENDED FOR EXTENDED PERIODS OF TIME.

**DO NOT SCALE DRAWING**

THIS DRAWING IS ISSUED IN CONFIDENCE AND CANNOT BE REPRODUCED OR USED TO MANUFACTURE ANYTHING SHOWN OR REFERRED TO WITHOUT DIRECT WRITTEN PERMISSION FROM NELSEN CORPORATION.

<b>NELSEN</b> CORPORATION		<b>NELSEN CORPORATION</b> OHIO • ARIZONA • TEXAS • FLORIDA 3250 BARBER RD - NORTON, OH 44203 800-362-9686 NELSENCORP.COM/COMMERCIAL
GENERAL ARRANGEMENT DWG. SOFTENER 450K DUPLEX NXT SYSTEM		
DRAWN BY:	RAR	DWG. NO. <b>29/17NXT-DUP-450-C3948</b>
DATE:	03-03-17	
CHECKED BY:		
PAGE 1 OF 1	REV:	