

# SOFTENER

MODEL NO. 315/18M-210

**CAPACITY:**

MIN. 168,000 grs. @ 10 lbs./cu.ft.  
 MAX. 210,000 grs. @ 15 lbs./cu.ft.

**FLOW RATE:**

NORMAL 55 gpm.  
 PEAK 77 gpm.  
 BACKWASH 12 gpm.

TANK SIZE: 21" x 62"  
 COMPOSITE

**MEDIA:**

RESIN 7 cu.ft.  
 GRAVEL 150 lbs.

**PIPE SIZE:**

INLET 2"  
 OUTLET 2"  
 DRAIN 2"  
 BRINE 1"  
 METER 2"

**BRINE TANK**

MODEL NO. BT2450R-454HF-5

TANK SIZE: 24" x 50"

POLYETHYLENE

**CAPACITY:**

100 gals.  
 850 lbs./salt

BRINE VALVE: 454HF

BRINE WELL: 5"

**WEIGHT (APPROX)**

TOTAL SHIPPING 821 lbs.

**SPACE REQUIRED (APPROX)**

49"L X 24"W X 74"H

**NOTE:**

ALL DASHED PIPE, VALVES,  
 AND FITTINGS NOT PROVIDED  
 BY NELSEN CORPORATION.

PEAK FLOWS ARE NOT  
 RECOMMENDED FOR EXTENDED  
 PERIODS OF TIME.

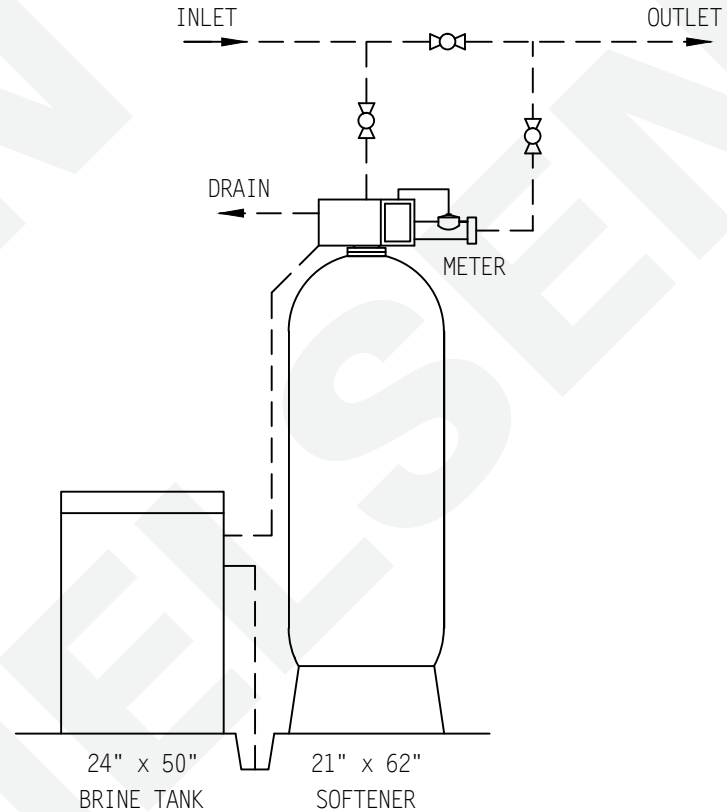

**DO NOT SCALE DRAWING**

THIS DRAWING IS ISSUED IN CONFIDENCE AND CANNOT BE REPRODUCED OR USED TO MANUFACTURE ANYTHING SHOWN OR REFERRED TO WITHOUT DIRECT WRITTEN PERMISSION FROM NELSEN CORPORATION.

|                          |               |  |
|--------------------------|---------------|--|
| <b>NELSEN</b>            |               | <b>NELSEN CORPORATION</b>  |
| CORPORATION              |               | OHIO • ARIZONA • TEXAS • FLORIDA<br>3250 BARBER RD - NORTON, OH 44203<br>800-362-9686<br>NELSENCORP.COM/COMMERCIAL |
| GENERAL ARRANGEMENT DWG. |               |  |
| SOFTENER 210K            |               |  |
| SYSTEM 4-METER           |               |  |
| DRAWN BY:                | R. ROBESON    | DWG. NO.   |
| DATE:                    | 07-11-07      | <b>315/18M-210-C2450</b>   |
| CHECKED BY:              |               |  |
| PAGE 1 OF 1              | REV: 06-21-12 |  |