

# SOFTENER

MODEL NO. MT315/18M-300

**CAPACITY:**

MIN. 240,000 grs. @ 10 lbs./cu.ft.  
 MAX. 300,000 grs. @ 15 lbs./cu.ft.

**FLOW RATE:**

NORMAL 60 gpm.  
 PEAK 95 gpm.  
 BACKWASH 15 gpm.

TANK SIZE: 24" x 72"  
 COMPOSITE

**MEDIA:**

RESIN 10 cu.ft.  
 GRAVEL 250 lbs.

**PIPE SIZE:**

INLET 2"  
 OUTLET 2"  
 DRAIN 2"  
 BRINE 1"  
 METER 2"

**BRINE TANK**

MODEL NO. BT3048R-494-5

TANK SIZE: 30" x 48"

POLYETHYLENE

**CAPACITY:**

145 gals.  
 1,200 lbs./salt

BRINE VALVE: 494

BRINE WELL: 5"

**WEIGHT (APPROX)**

TOTAL SHIPPING 1,150 lbs.

**SPACE REQUIRED (APPROX)**

58"L X 30"W X 85"H

**NOTE:**

ALL DASHED PIPE, VALVES,  
 AND FITTINGS NOT PROVIDED  
 BY NELSEN CORPORATION.

PEAK FLOWS ARE NOT  
 RECOMMENDED FOR EXTENDED  
 PERIODS OF TIME.

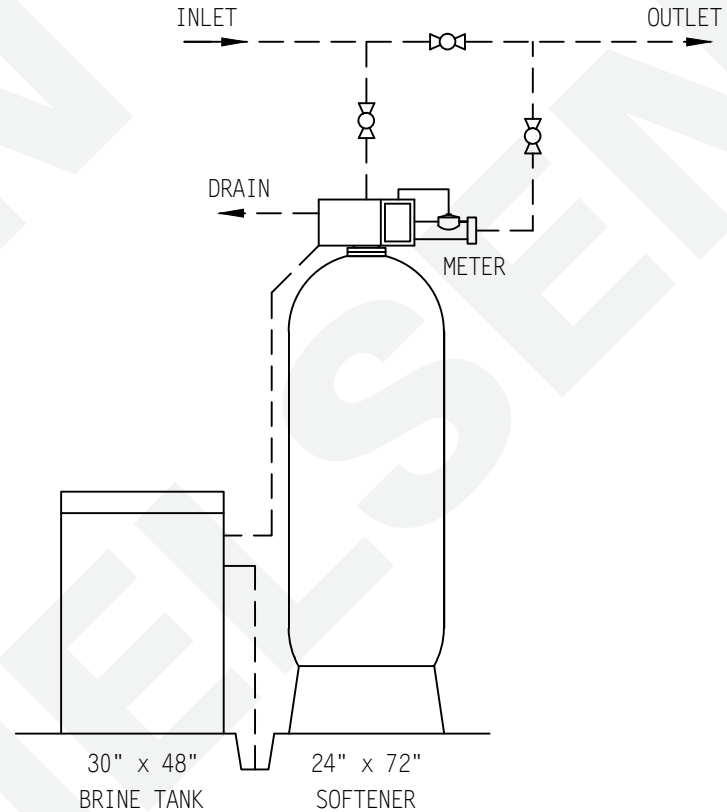

**DO NOT SCALE DRAWING**

THIS DRAWING IS ISSUED IN CONFIDENCE AND CANNOT BE REPRODUCED OR USED TO MANUFACTURE ANYTHING SHOWN OR REFERRED TO WITHOUT DIRECT WRITTEN PERMISSION FROM NELSEN CORPORATION.

<b>NELSEN CORPORATION</b>		OHIO • ARIZONA • TEXAS • FLORIDA 3250 BARBER RD - NORTON, OH 44203 800-362-9686 NELSENCORP.COM/COMMERCIAL
GENERAL ARRANGEMENT DWG. SOFTENER 300K SYSTEM 4-METER		
DRAWN BY:	R. ROBESON	DWG. NO.
DATE:	07-11-07	315/18M-300-C3048
CHECKED BY:		
PAGE 1 OF 1	REV: 06-21-12	