

SOFTENER

MODEL NO. MT315/18M-450

CAPACITY:

MIN. 360,000 grs. @ 10 lbs./cu.ft.
 MAX. 450,000 grs. @ 15 lbs./cu.ft.

FLOW RATE:

NORMAL 75 gpm.
 PEAK 105 gpm.
 BACKWASH 25 gpm.

TANK SIZE: 30" x 72"
 COMPOSITE

MEDIA:

RESIN 15 cu.ft.
 GRAVEL 350 lbs.

PIPE SIZE:

INLET 2"
 OUTLET 2"
 DRAIN 2"
 BRINE 1"
 METER 2"

BRINE TANK

MODEL NO. BT3948R-494-5

TANK SIZE: 39" x 48"

POLYETHYLENE

CAPACITY:

250 gals.
 2,200 lbs./salt

BRINE VALVE: 494

BRINE WELL: 5"

WEIGHT (APPROX)

TOTAL SHIPPING 1,615 lbs.

SPACE REQUIRED (APPROX)

73"L X 39"W X 92"H

NOTE:

ALL DASHED PIPE, VALVES,
 AND FITTINGS NOT PROVIDED
 BY NELSEN CORPORATION.

PEAK FLOWS ARE NOT
 RECOMMENDED FOR EXTENDED
 PERIODS OF TIME.

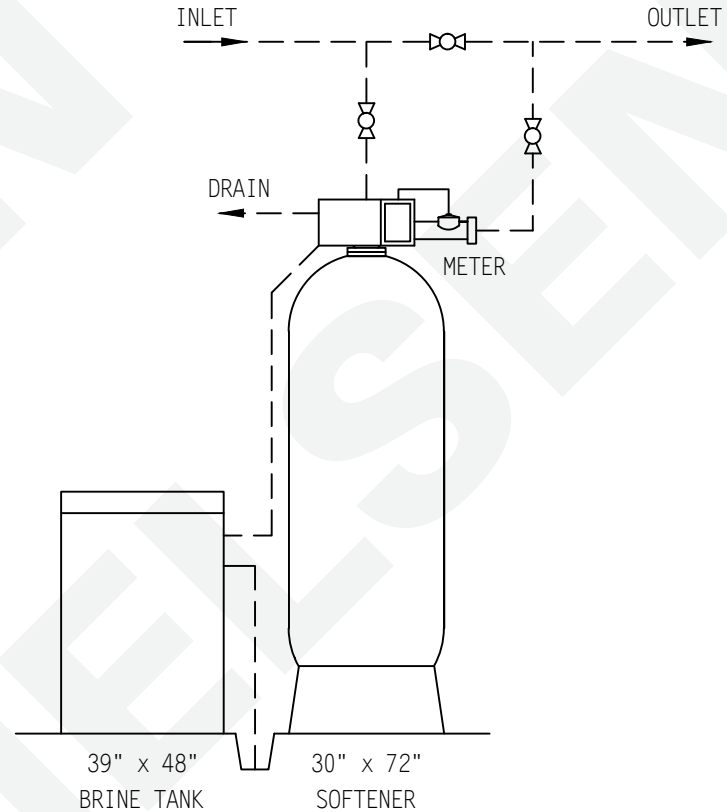

DO NOT SCALE DRAWING

THIS DRAWING IS ISSUED IN CONFIDENCE AND CANNOT BE REPRODUCED OR USED TO MANUFACTURE ANYTHING SHOWN OR REFERRED TO WITHOUT DIRECT WRITTEN PERMISSION FROM NELSEN CORPORATION.

| | | | |
|---|------------------------|---|--|
| | | NELSEN CORPORATION 3250 BARBER RD - NORTON, OH 44203 800-362-9686 nelsencorp.com/commercial • OHIO • ARIZONA • TEXAS • FLORIDA | |
| GENERAL ARRANGEMENT DWG. SOFTENER 450K SYSTEM 4-METER | | | |
| DRAWN BY: DATE: CHECKED BY: PAGE 1 OF 1 | R. ROBESON 07-11-07 | DWG. NO. 315/18M-450-C3948 | |