

SOFTENER

MODEL NO. MT315/18M-900

CAPACITY:

MIN. 720,000 grs. @ 10 lbs./cu.ft.
 MAX. 900,000 grs. @ 15 lbs./cu.ft.

FLOW RATE:

NORMAL 85 gpm.
 PEAK 120 gpm.
 BACKWASH 50 gpm.

TANK SIZE: 42" x 72"
 COMPOSITE

MEDIA:

RESIN 30 cu.ft.
 GRAVEL 700 lbs.

PIPE SIZE:

INLET 2"
 OUTLET 2"
 DRAIN 2"
 BRINE 1"
 METER 2"

BRINE TANK

MODEL NO. BT5060R-494-5

TANK SIZE: 50" x 60"

POLYETHYLENE

CAPACITY:

500 gals.
 4,500 lbs./salt

BRINE VALVE: 494

BRINE WELL: 5"

WEIGHT (APPROX)

TOTAL SHIPPING 3,050 lbs.

SPACE REQUIRED (APPROX)

96"L X 50"W X 96"H

NOTE:

ALL DASHED PIPE, VALVES,
 AND FITTINGS NOT PROVIDED
 BY NELSEN CORPORATION.

PEAK FLOWS ARE NOT
 RECOMMENDED FOR EXTENDED
 PERIODS OF TIME.

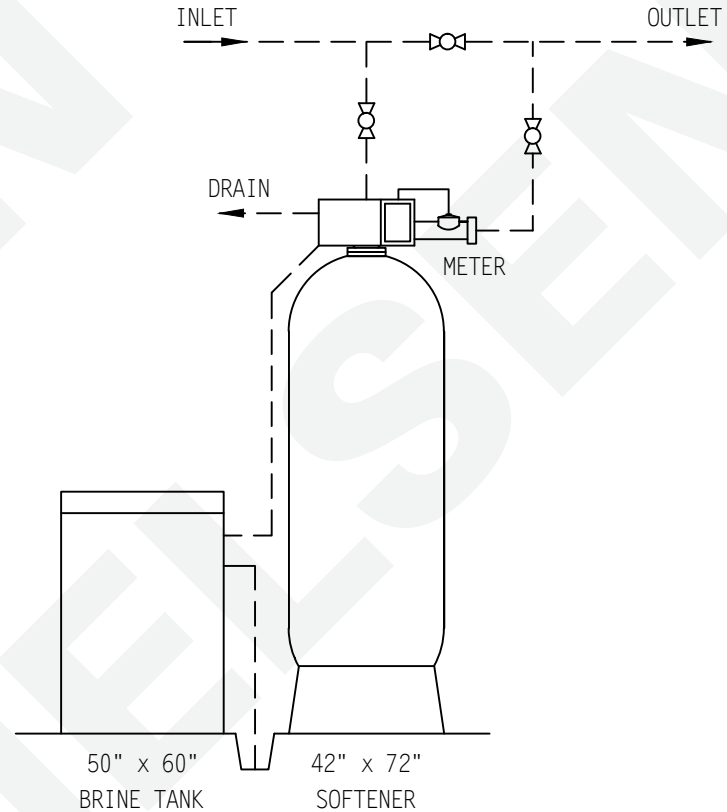

DO NOT SCALE DRAWING

THIS DRAWING IS ISSUED IN CONFIDENCE AND CANNOT BE REPRODUCED OR USED TO MANUFACTURE ANYTHING SHOWN OR REFERRED TO WITHOUT DIRECT WRITTEN PERMISSION FROM NELSEN CORPORATION.

	NELSEN CORPORATION 3250 BARBER RD - NORTON, OH 44203 800-362-9686 OHIO • ARIZONA • TEXAS • FLORIDA	
	GENERAL ARRANGEMENT DWG. SOFTENER 900K SYSTEM 4-METER	

DRAWN BY:	R. ROBESON
DATE:	07-11-07
CHECKED BY:	
PAGE 1 OF 1	REV: 06-22-12

DWG. NO.
315/18M-900-C5060