

# TWIN ALTERNATING SOFTENER

MODEL NO. NCSMF-29/17NXT2-TA-210-C2450

**CAPACITY:**

MIN. 168,000 grs. @ 10 lbs./cu.ft. (each tank)  
 MAX. 210,000 grs. @ 15 lbs./cu.ft. (each tank)

**FLOW RATE:**

NORMAL 55 gpm.  
 PEAK 77 gpm.  
 BACKWASH 12 gpm.

TANK SIZE: 21" x 62"

100 PSI COMPOSITE

**MEDIA:**

RESIN 7 cu.ft. (each tank)  
 GRAVEL 150 lbs. (each tank)

**PIPE SIZE: PVC**

INLET 2"  
 OUTLET 2"  
 DRAIN 1"  
 BRINE 1/2"  
 METER 2"

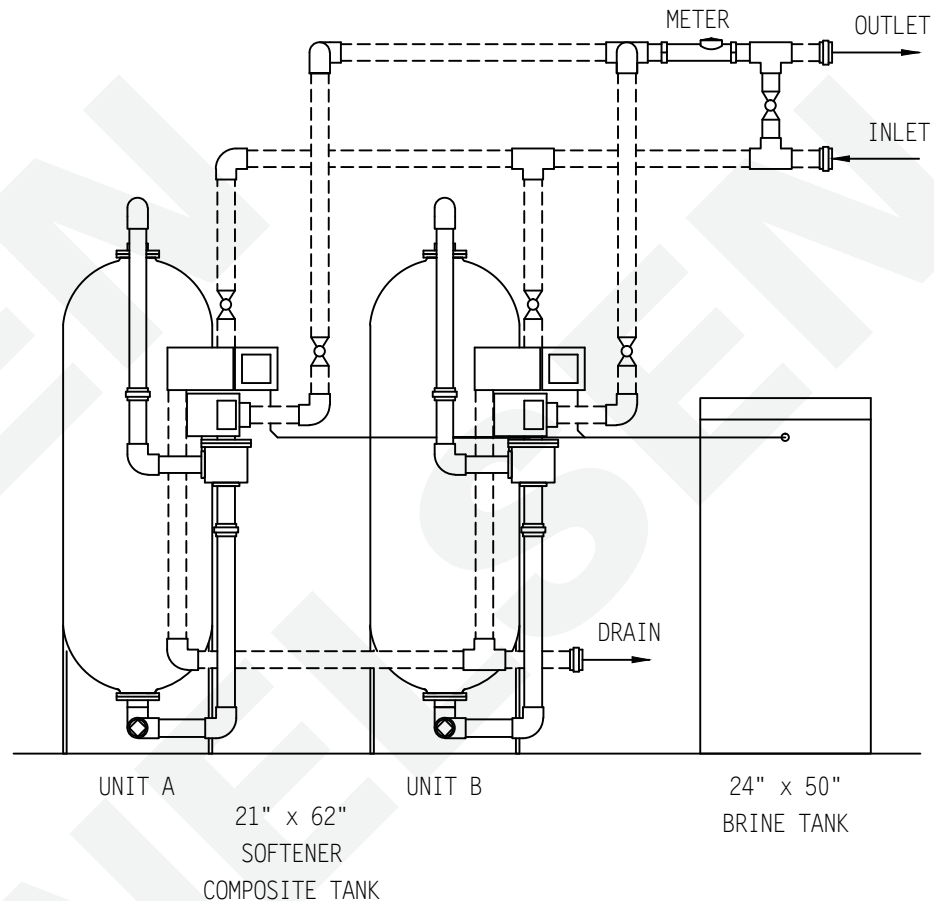

**BRINE TANK**

MODEL NO. BT2450R-454HF-5

TANK SIZE: 24" x 50"

POLYETHYLENE

**CAPACITY:**

100 gals.  
 900 lbs./salt

BRINE VALVE: 454HF

BRINE WELL: 5"

WEIGHT (APPROX)

TOTAL SHIPPING 1,440 lbs.

**NOTE:**

ALL DASHED PIPE, VALVES, AND FITTINGS NOT PROVIDED BY NELSEN CORPORATION.

**SPACE REQUIRED (APPROX)**

74"L x 34"W x 79"H

PEAK FLOWS ARE NOT RECOMMENDED FOR EXTENDED PERIODS OF TIME.

**DO NOT SCALE DWG.**

THIS DRAWING IS ISSUED IN CONFIDENCE AND CANNOT BE REPRODUCED OR USED TO MANUFACTURE ANYTHING SHOWN OR REFERRED TO WITHOUT DIRECT WRITTEN PERMISSION FROM NELSEN CORPORATION.

**NELSEN**  
CORPORATION

NELSEN CORPORATION  
 5151 PORTSIDE DR - MEDINA, OH 44256  
 800-362-9686  
 OHIO • ARIZONA • TEXAS • FLORIDA

GENERAL ARRANGEMENT DWG.  
 SOFTENER 210K COMPOSITE TANK  
 SYSTEM 7 ALTERNATING

DRAWN BY:	RAR
DATE:	01-06-17
CHECKED BY:	
PAGE 1 OF 1	REV:

DWG. NO.  
 NCSMF-29/17NXT2-TA-210-C2450