

TWIN ALTERNATING SOFTENER

MODEL NO. NCSMF-29/17NXT2-TA-450-C3948

CAPACITY:

MIN. 360,000 grs. @ 10 lbs./cu.ft. (each tank)
 MAX. 450,000 grs. @ 15 lbs./cu.ft. (each tank)

FLOW RATE:

NORMAL 75 gpm. (each tank)
 PEAK 140 gpm. (each tank)
 BACKWASH 25 gpm. (each tank)

TANK SIZE: 30" x 72"

100 PSI COMPOSITE

MEDIA:

RESIN 15 cu.ft. (each tank)
 GRAVEL 350 lbs. (each tank)

PIPE SIZE: PVC

INLET 2"
 OUTLET 2"
 DRAIN 1"
 BRINE 1/2"
 METER 3"

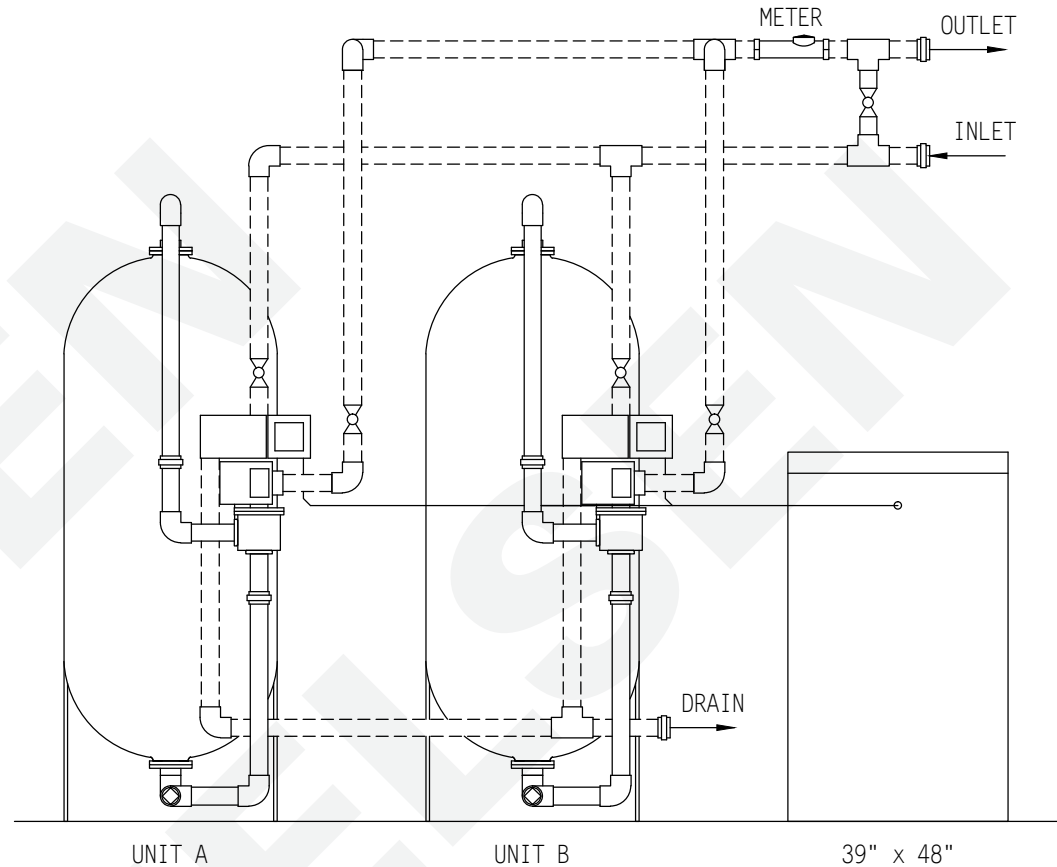

BRINE TANK

MODEL NO. BT3948R-454HF-5

TANK SIZE: 39" x 48"

POLYETHYLENE

CAPACITY:

250 gals.
 2,200 lbs./salt

BRINE VALVE: 454HF

BRINE WELL: 5"

WEIGHT (APPROX)

TOTAL SHIPPING 3,085 lbs.

NOTE:

ALL DASHED PIPE, VALVES, AND FITTINGS NOT PROVIDED BY NELSEN CORPORATION.

SPACE REQUIRED (APPROX)

107"L x 49"W x 93"H

PEAK FLOWS ARE NOT RECOMMENDED FOR EXTENDED PERIODS OF TIME.

DO NOT SCALE DWG.

THIS DRAWING IS ISSUED IN CONFIDENCE AND CANNOT BE REPRODUCED OR USED TO MANUFACTURE ANYTHING SHOWN OR REFERRED TO WITHOUT DIRECT WRITTEN PERMISSION FROM NELSEN CORPORATION.

NELSEN
CORPORATION

NELSEN CORPORATION
 5151 PORTSIDE DR - MEDINA, OH 44256
 800-362-9686
 OHIO • ARIZONA • TEXAS • FLORIDA

GENERAL ARRANGEMENT DWG.
 SOFTENER 450K COMPOSITE TANK
 SYSTEM 7 ALTERNATING

DRAWN BY:	RAR
DATE:	01-06-17
CHECKED BY:	
PAGE 1 OF 1	REV:

DWG. NO.
 NCSMF-29/17NXT2-TA-450-C3948