

METER SOFTENER

MODEL NO. 39/18NXT2-300-C3048

CAPACITY:

MIN. 240,000 grs. @ 10 lbs./cu.ft.
 MAX. 300,000 grs. @ 15 lbs./cu.ft.

FLOW RATE:

NORMAL 120 gpm.
 PEAK 170 gpm.
 BACKWASH 15 gpm.

TANK SIZE: 24" x 72"

COMPOSITE

MEDIA:

RESIN 10 cu.ft.
 GRAVEL 250 lbs.

PIPE SIZE:

INLET 3"
 OUTLET 3"
 DRAIN 2"
 BRINE 1"
 METER 3"

BRINE TANK

MODEL NO. BT3048R-494-5
 TANK SIZE: 30"x 48"
 POLYETHYLENE

CAPACITY:

145 gals.
 1,200 lbs./salt

BRINE VALVE: 494

BRINE WELL: 5"

WEIGHT (APPROX)

TOTAL SHIPPING 1,250 lbs.

NOTE:

ALL DASHED PIPE, VALVES,
 AND FITTINGS NOT PROVIDED
 BY NELSEN CORPORATION.

SPACE REQUIRED (APPROX)
 58"L x 30"W x 92"H

PEAK FLOWS ARE NOT
 RECOMMENDED FOR EXTENDED
 PERIODS OF TIME.

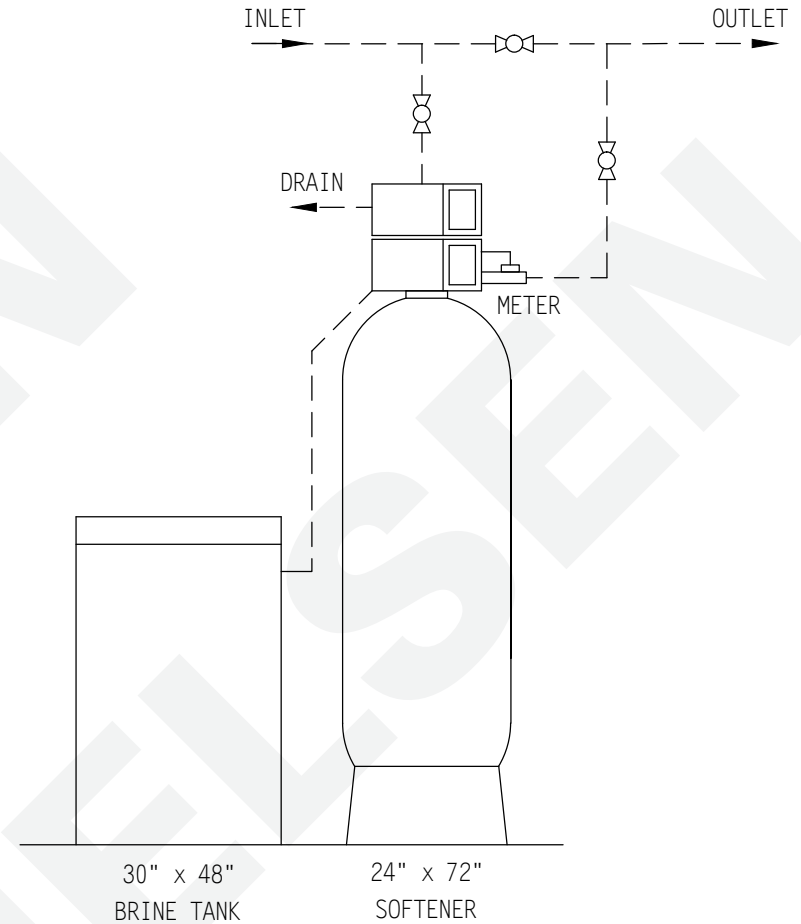

DO NOT SCALE DRAWING

THIS DRAWING IS ISSUED IN CONFIDENCE AND
 CANNOT BE REPRODUCED OR USED TO
 MANUFACTURE ANYTHING SHOWN OR REFERRED
 TO WITHOUT DIRECT WRITTEN PERMISSION FROM
 NELSEN CORPORATION.

		NELSEN CORPORATION OHIO • ARIZONA • TEXAS • FLORIDA 5151 PORTSIDE DRIVE - MEDINA, OH 44256 800-362-9686 NELSENCORP.COM/COMMERCIAL	
		GENERAL ARRANGEMENT DWG. SOFTENER 300K COMPOSITE TANK SYSTEM 4-METER	
DRAWN BY: RAR	DATE: 03-08-17	DWG. NO. 39/18NXT2-300-C3048	
CHECKED BY:	REV:		
PAGE 1 OF 1	REV:		