

# DUPLEX NXT2 SOFTENER

MODEL NO. 39/18NXT2-DUP-900-C5060

CAPACITY: (each tank)

MIN. 720,000 grs. @ 10 lbs./cu.ft.

MAX. 900,000 grs. @ 15 lbs./cu.ft.

FLOW RATE: (each tank)

NORMAL 200 gpm.

PEAK 270 gpm.

BACKWASH 50 gpm.

TANK SIZE: 42" x 72"

COMPOSITE

MEDIA: (each tank)

RESIN 30 cu.ft.

GRAVEL 700 lbs.

PIPE SIZE:

INLET 3"

OUTLET 3"

DRAIN 2"

BRINE 1"

METER 3"

## BRINE TANK

MODEL NO. BT5060R-494-5

TANK SIZE: 50" x 60"

POLYETHYLENE

CAPACITY:

500 gals.

4,500 lbs./salt

BRINE VALVE: 494

BRINE WELL: 5"

WEIGHT (APPROX)

TOTAL SHIPPING 6,720 lbs.

## NOTE:

ALL DASHED PIPE, VALVES, AND FITTINGS NOT PROVIDED BY NELSEN CORPORATION.

SPACE REQUIRED (APPROX)

142"L x 50"W x 101"H

PEAK FLOWS ARE NOT RECOMMENDED FOR EXTENDED PERIODS OF TIME.

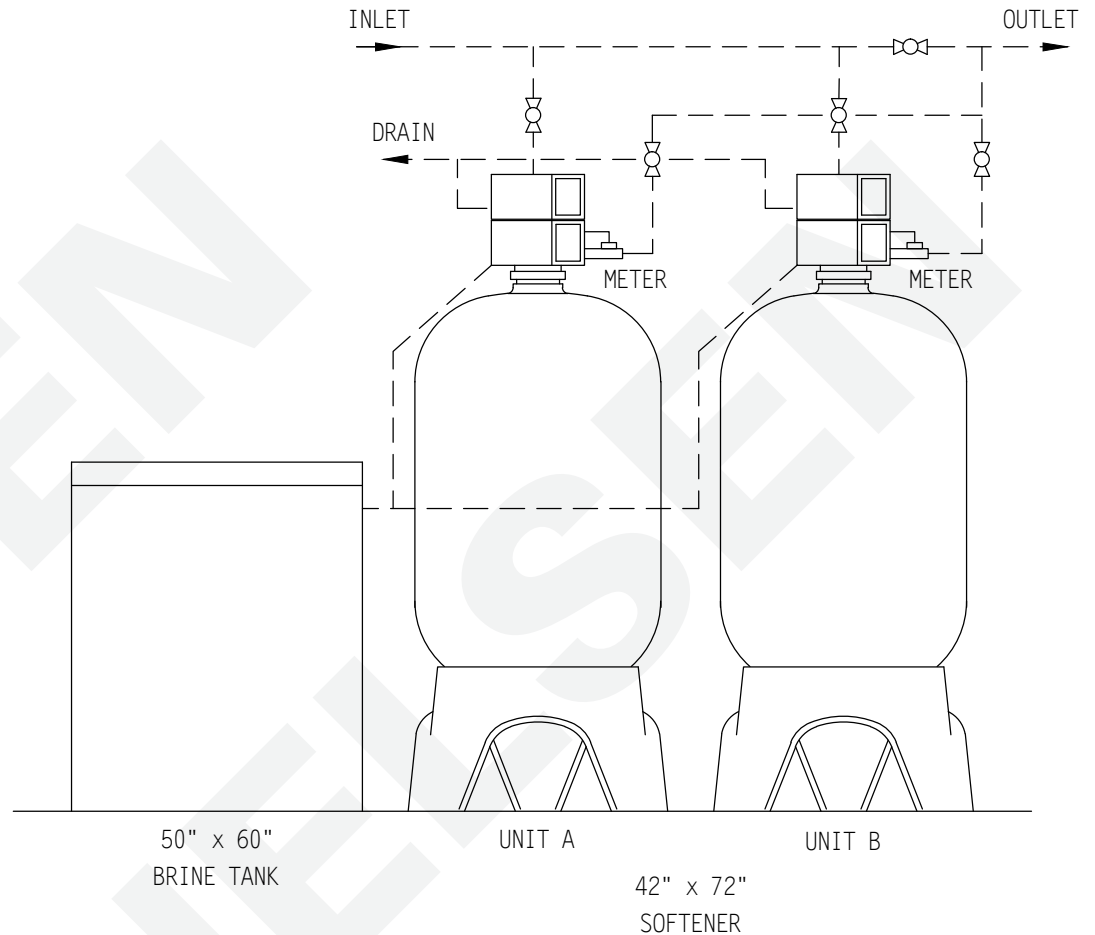

**DO NOT SCALE DRAWING**

THIS DRAWING IS ISSUED IN CONFIDENCE AND CANNOT BE REPRODUCED OR USED TO MANUFACTURE ANYTHING SHOWN OR REFERRED TO WITHOUT DIRECT WRITTEN PERMISSION FROM NELSEN CORPORATION.

**NELSEN**  
CORPORATION

**NELSEN CORPORATION**  
OHIO • ARIZONA • TEXAS • FLORIDA  
5151 PORTSIDE DRIVE - MEDINA, OH 44256  
800-362-9686  
NELSENCORP.COM/COMMERCIAL

GENERAL ARRANGEMENT DWG.  
SOFTENER 900K COMPOSITE TANK  
DUPLEX NXT2 SYSTEM

DRAWN BY:	RAR	DWG. NO.
DATE:	03-13-17	39/18NXT2-DUP-900-C5060
CHECKED BY:		
PAGE 1 OF 1	REV:	