

TWIN ALTERNATING SOFTENER

MODEL NO. 39/18NXT7-900-C5060

CAPACITY: (each tank)

MIN. 720,000 grs. @ 10 lbs./cu.ft.

MAX. 900,000 grs. @ 15 lbs./cu.ft.

FLOW RATE: (each tank)

NORMAL 200 gpm.

PEAK 270 gpm.

BACKWASH 50 gpm.

TANK SIZE: 42" x 72"

COMPOSITE

MEDIA: (each tank)

RESIN 30 cu.ft.

GRAVEL 700 lbs.

PIPE SIZE:

INLET 3"

OUTLET 3"

DRAIN 2"

BRINE 1"

METER 3"

BRINE TANK

MODEL NO. BT5060R-494-5

TANK SIZE: 50" x 60"

POLYETHYLENE

CAPACITY:

500 gals.

4,500 lbs./salt

BRINE VALVE: 494

BRINE WELL: 5"

WEIGHT (APPROX)

TOTAL SHIPPING 6,690 lbs.

NOTE:

ALL DASHED PIPE, VALVES, AND FITTINGS NOT PROVIDED BY NELSEN CORPORATION.

SPACE REQUIRED (APPROX)

142"L x 50"W x 101"H

PEAK FLOWS ARE NOT RECOMMENDED FOR EXTENDED PERIODS OF TIME.

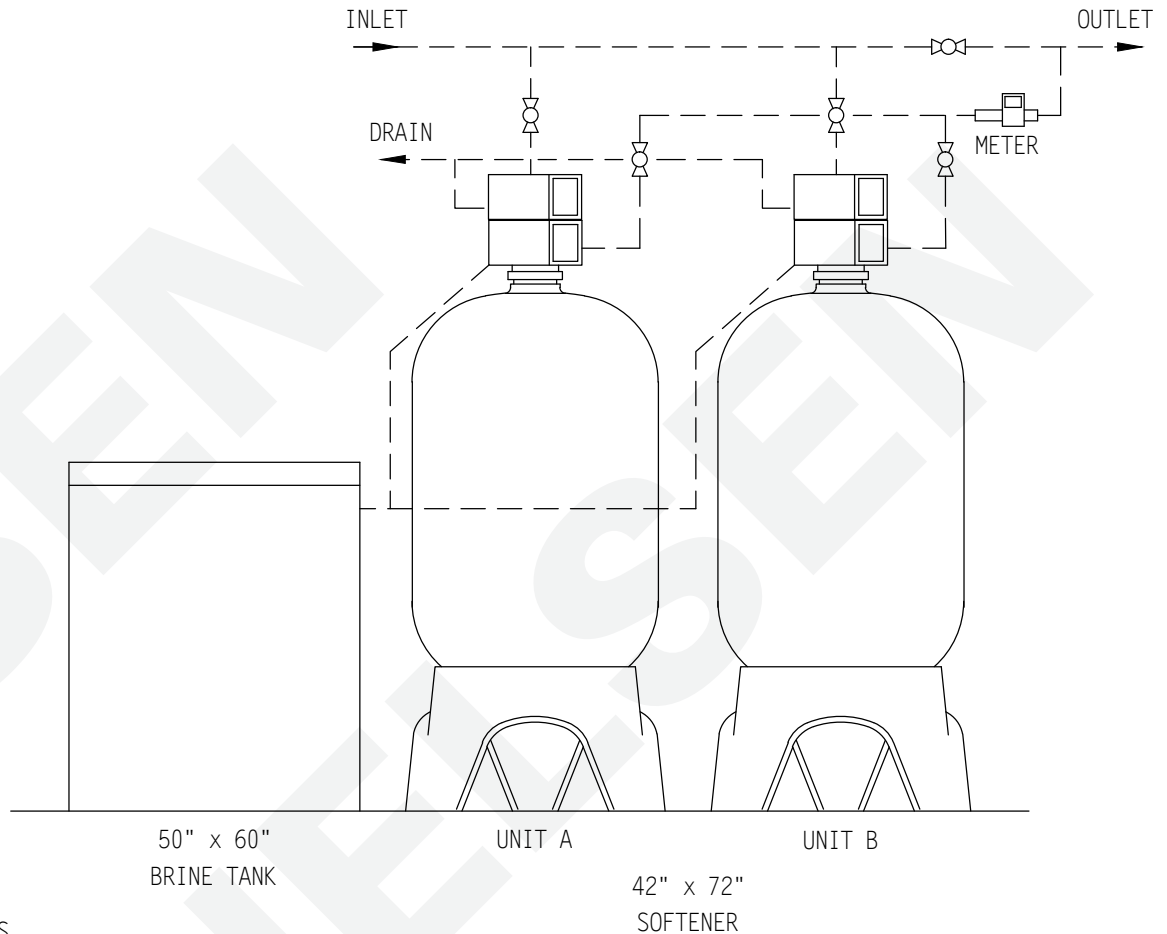

DO NOT SCALE DRAWING

THIS DRAWING IS ISSUED IN CONFIDENCE AND CANNOT BE REPRODUCED OR USED TO MANUFACTURE ANYTHING SHOWN OR REFERRED TO WITHOUT DIRECT WRITTEN PERMISSION FROM NELSEN CORPORATION.

NELSEN
CORPORATION

NELSEN CORPORATION
OHIO • ARIZONA • TEXAS • FLORIDA
5151 PORTSIDE DRIVE - MEDINA, OH 44256
800-362-9686
NELSENCORP.COM/COMMERCIAL

GENERAL ARRANGEMENT DWG.
SOFTENER 900K COMPOSITE TANK
SYSTEM 7 ALTERNATING

DRAWN BY:	RAR
DATE:	03-10-17
CHECKED BY:	
PAGE 1 OF 1	REV:

DWG. NO.
39/18NXT7-900-C5060