

# SOFTENER

MODEL NO. 95/17M-210-C2450

**CAPACITY:**

MIN. 168,000 grs. @ 10 lbs./cu.ft.  
 MAX. 210,000 grs. @ 15 lbs./cu.ft.

**FLOW RATE:**

NORMAL 35 gpm.  
 PEAK 55 gpm.  
 BACKWASH 12 gpm.

TANK SIZE: 21" x 62"

COMPOSITE

**MEDIA:**

RESIN 7 cu.ft.  
 GRAVEL 150 lbs.

**PIPE SIZE"**

INLET 1-1/2"  
 OUTLET 1-1/2"  
 DRAIN 1"  
 BRINE 1/2"  
 METER 1-1/2"

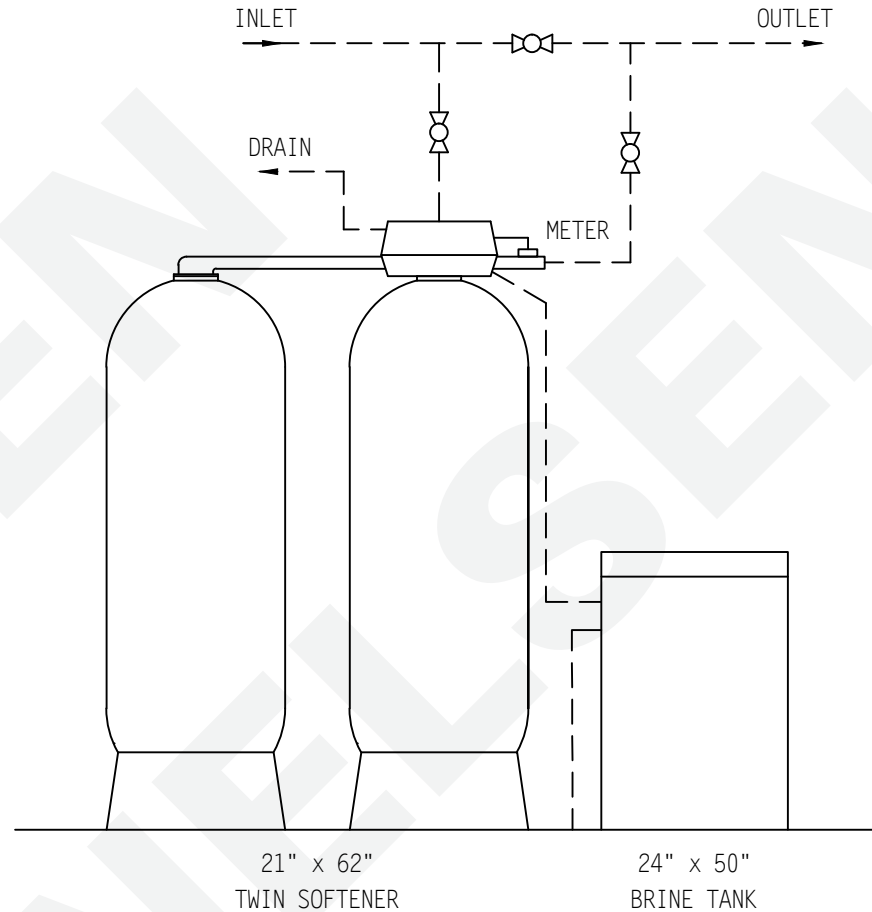

**BRINE TANK**

MODEL NO. BT2450R-454HF-5

TANK SIZE: 24" x 50"

POLYETHYLENE

**CAPACITY:**

100 gal.s.  
 900 lbs./salt

BRINE VALVE: 454HF

BRINE WELL: 5"

**WEIGHT (APPROX)**

TOTAL SHIPPING 1,411 lbs.  
 TOTAL OPERATING 2,970 lbs.

**NOTE:**

ALL DASHED PIPE, VALVES,  
 AND FITTINGS NOT PROVIDED  
 BY NELSEN CORPORATION.

**SPACE REQUIRED (APPROX)**

75"L x 24"W x 77"H

PEAK FLOWS ARE NOT  
 RECOMMENDED FOR EXTENDED  
 PERIODS OF TIME.

**DO NOT SCALE DWG.**

THIS DRAWING IS ISSUED IN CONFIDENCE AND  
 CANNOT BE REPRODUCED OR USED TO  
 MANUFACTURE ANYTHING SHOWN OR REFERRED  
 TO WITHOUT DIRECT WRITTEN PERMISSION FROM  
 NELSEN CORPORATION.

	<b>NELSEN CORPORATION</b> OHIO • ARIZONA • TEXAS • FLORIDA 5151 PORTSIDE DRIVE - MEDINA, OH 4425 800-362-9686 NELSENCORP.COM/COMMERCIAL	
	GENERAL ARRANGEMENT DWG. SOFTENER 210K 9500 TWIN TANK	

GENERAL ARRANGEMENT DWG.  
 SOFTENER 210K  
 9500 TWIN TANK

DRAWN BY:	R. ROBESON
DATE:	08-26-09
CHECKED BY:	
PAGE 1 OF 1	REV: 10-09-14

DWG. NO.  
 95/17M-210-C2450