

SOFTENER

MODEL NO. 95/17M-80-C1840

CAPACITY:

MIN. 60,000 grs. @ 10 lbs./cu.ft.
 MAX. 80,000 grs. @ 15 lbs./cu.ft.

FLOW RATE:

NORMAL 28 gpm.
 PEAK 39 gpm.
 BACKWASH 4 gpm.

TANK SIZE: 13" x 54"

COMPOSITE

MEDIA:

RESIN 2.5 cu.ft.
 GRAVEL 35 lbs.

PIPE SIZE"

INLET 1-1/2"
 OUTLET 1-1/2"
 DRAIN 1"
 BRINE 1/2"
 METER 1-1/2"

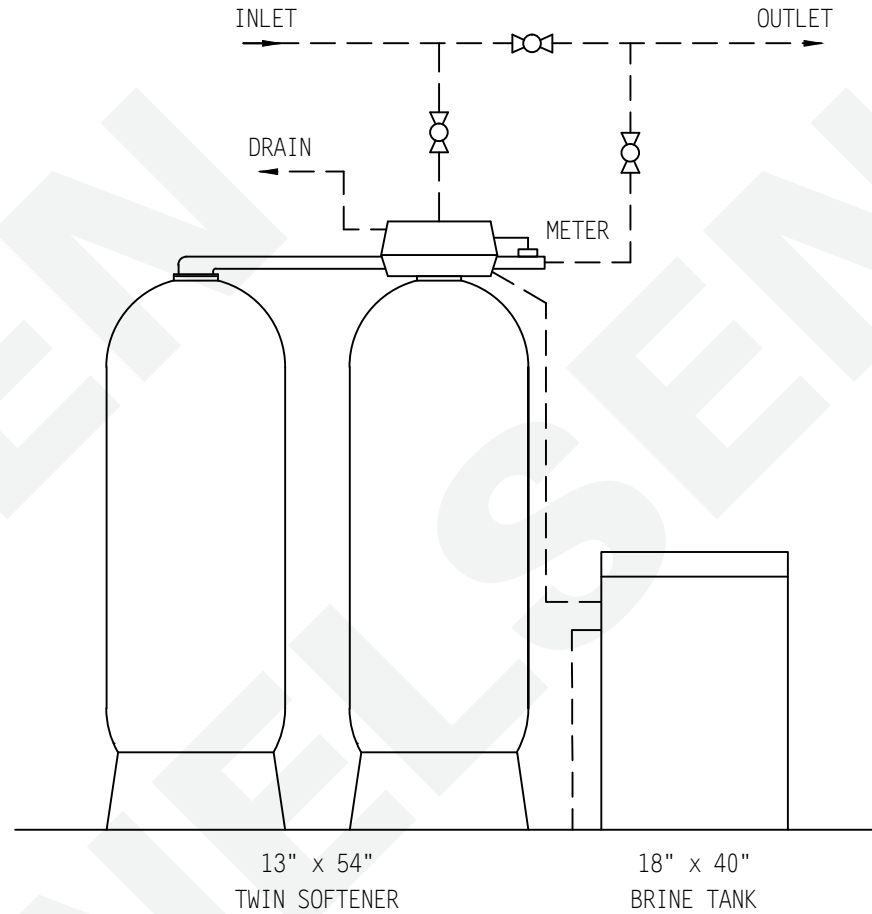

BRINE TANK

MODEL NO. BT1840R-454HF-5

TANK SIZE: 18" x 40"

POLYETHYLENE

CAPACITY:

43 gals.
 450 lbs./salt

BRINE VALVE: 454

BRINE WELL: 5"

WEIGHT (APPROX)

TOTAL SHIPPING 306 lbs.

NOTE:

ALL DASHED PIPE, VALVES,
 AND FITTINGS NOT PROVIDED
 BY NELSEN CORPORATION.

SPACE REQUIRED (APPROX)

52"L x 18"W x 66"H

PEAK FLOWS ARE NOT
 RECOMMENDED FOR EXTENDED
 PERIODS OF TIME.

DO NOT SCALE DWG.

THIS DRAWING IS ISSUED IN CONFIDENCE AND
 CANNOT BE REPRODUCED OR USED TO
 MANUFACTURE ANYTHING SHOWN OR REFERRED
 TO WITHOUT DIRECT WRITTEN PERMISSION FROM
 NELSEN CORPORATION.

		NELSEN CORPORATION OHIO • ARIZONA • TEXAS • FLORIDA 5151 PORTSIDE DRIVE - MEDINA, OH 4425 800-362-9686 NELSENCORP.COM/COMMERCIAL	
		GENERAL ARRANGEMENT DWG. SOFTENER 80K 9500 TWIN TANK	
DRAWN BY: DATE: CHECKED BY: PAGE 1 OF 1	R. ROBESON 08-30-12 REV: 10-09-14	DWG. NO. 95/17M-80-C1840	