

NXT2 SOFTENER

MODEL NO. NCSMF-39/18NXT2-1200-C5060

CAPACITY:

MIN. 960,000 grs. @ 10 lbs./cu.ft.
 MAX. 1,200,000 grs. @ 15 lbs./cu.ft.

FLOW RATE:

NORMAL 205 gpm.
 PEAK 280 gpm.
 BACKWASH 65 gpm.

TANK SIZE: 48" x 72"

COMPOSITE

MEDIA:

RESIN 40 cu.ft.
 GRAVEL 900 lbs.

PIPE SIZE" PVC

MATERIAL

INLET 3"
 OUTLET 3"
 DRAIN 2"
 BRINE 1"
 METER 3"

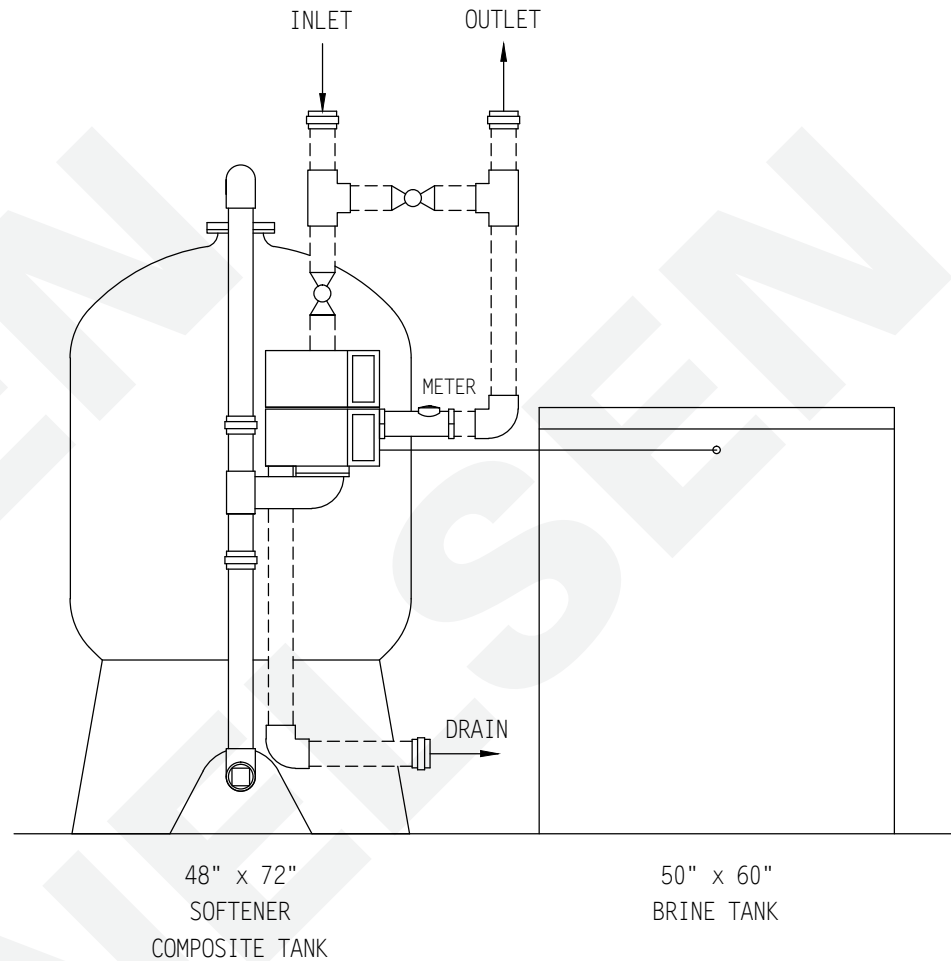

BRINE TANK

MODEL NO. BT5060R-494-5

TANK SIZE: 50" x 60"

POLYETHYLENE

CAPACITY:

500 gals.
 4500 lbs./salt

BRINE VALVE: 494

BRINE WELL: 5"

WEIGHT (APPROX)

TOTAL SHIPPING 4,350 lbs.

NOTE:

ALL DASHED PIPE, VALVES,
 AND FITTINGS NOT PROVIDED
 BY NELSEN CORPORATION.

SPACE REQUIRED (APPROX)

102"L x 63"W x 106"H

PEAK FLOWS ARE NOT
 RECOMMENDED FOR EXTENDED
 PERIODS OF TIME.

DO NOT SCALE DWG.

THIS DRAWING IS ISSUED IN CONFIDENCE AND
 CANNOT BE REPRODUCED OR USED TO
 MANUFACTURE ANYTHING SHOWN OR REFERRED
 TO WITHOUT DIRECT WRITTEN PERMISSION FROM
 NELSEN CORPORATION.

		NELSEN CORPORATION OHIO • ARIZONA • TEXAS • FLORIDA 5151 PORTSIDE DRIVE - MEDINA, OH 44256 800-362-9686 NELSENCORP.COM/COMMERCIAL	
		GENERAL ARRANGEMENT DWG. SOFTENER 1200K COMPOSITE TANK SIMPLEX NXT2 SYSTEM	
DRAWN BY: RAR DATE: 01-30-17 CHECKED BY: PAGE 1 OF 1	REV: DWG. NO. NCSMF-39/18NXT2-1200-C5060		