

NXT2 SOFTENER

MODEL NO. NCSMF-39/18NXT2-300-C3048

CAPACITY:

MIN. 240,000 grs. @ 10 lbs./cu.ft.
 MAX. 300,000 grs. @ 15 lbs./cu.ft.

FLOW RATE:

NORMAL 120 gpm.
 PEAK 170 gpm.
 BACKWASH 15 gpm.

TANK SIZE: 24" x 72"

COMPOSITE

MEDIA:

RESIN 10 cu.ft.
 GRAVEL 250 lbs.

PIPE SIZE: PVC

MATERIAL

INLET 3"
 OUTLET 3"
 DRAIN 2"
 BRINE 1"
 METER 3"

BRINE TANK

MODEL NO. BT3048R-494-5

TANK SIZE: 30" x 48"

POLYETHYLENE

CAPACITY:

145 gals.
 1200 lbs./salt

BRINE VALVE: 494

BRINE WELL: 5"

WEIGHT (APPROX)

TOTAL SHIPPING 1,300 lbs.

NOTE:

ALL DASHED PIPE, VALVES,
 AND FITTINGS NOT PROVIDED
 BY NELSEN CORPORATION.

SPACE REQUIRED (APPROX)

58"L x 39"W x 92"H

PEAK FLOWS ARE NOT
 RECOMMENDED FOR EXTENDED
 PERIODS OF TIME.

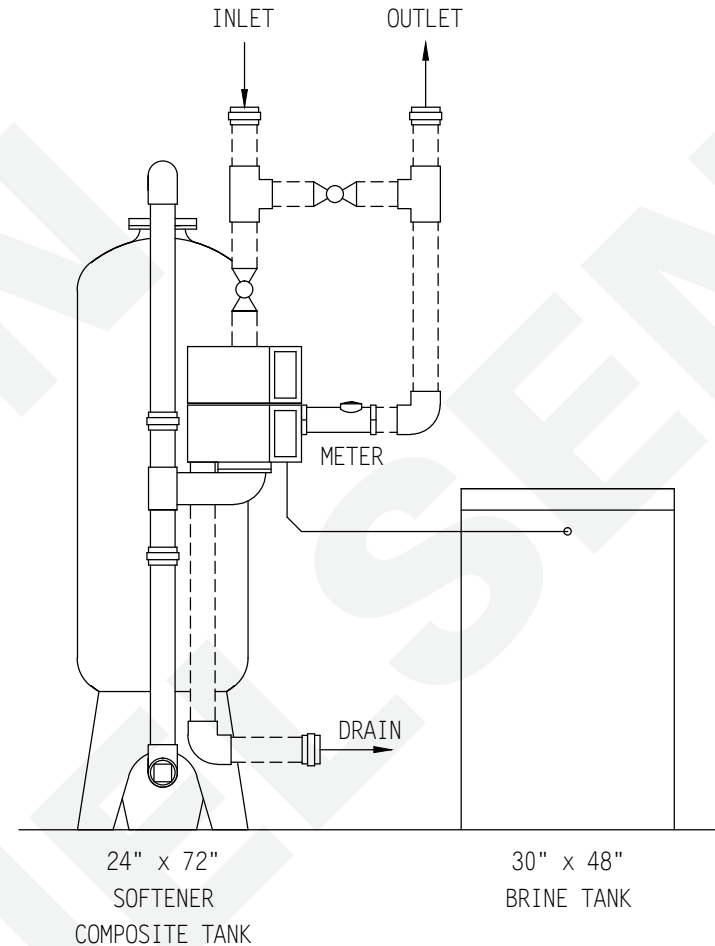

24" x 72"
 SOFTENER
 COMPOSITE TANK

30" x 48"
 BRINE TANK

DO NOT SCALE DWG.

THIS DRAWING IS ISSUED IN CONFIDENCE AND
 CANNOT BE REPRODUCED OR USED TO
 MANUFACTURE ANYTHING SHOWN OR REFERRED
 TO WITHOUT DIRECT WRITTEN PERMISSION FROM
 NELSEN CORPORATION.

NELSEN
 CORPORATION

NELSEN CORPORATION
 OHIO • ARIZONA • TEXAS • FLORIDA
 5151 PORTSIDE DRIVE - MEDINA, OH 44256
 800-362-9686
 NELSENCORP.COM/COMMERCIAL

GENERAL ARRANGEMENT DWG.
 SOFTENER 300K COMPOSITE TANK
 SIMPLEX NXT2 SYSTEM

DRAWN BY:	RAR
DATE:	01-27-17
CHECKED BY:	
PAGE 1 OF 1	REV:

DWG. NO.
NCSMF-39/18NXT2-300-C3048