

NXT2 SOFTENER

MODEL NO. NCSMF-39/18NXT2-900-C5060

CAPACITY:

MIN. 720,000 grs. @ 10 lbs./cu.ft.
 MAX. 900,000 grs. @ 15 lbs./cu.ft.

FLOW RATE:

NORMAL 200 gpm.
 PEAK 270 gpm.
 BACKWASH 50 gpm.

TANK SIZE: 42" x 72"

COMPOSITE

MEDIA:

RESIN 30 cu.ft.
 GRAVEL 700 lbs.

PIPE SIZE: PVC

MATERIAL

INLET 3"
 OUTLET 3"
 DRAIN 2"
 BRINE 1"
 METER 3"

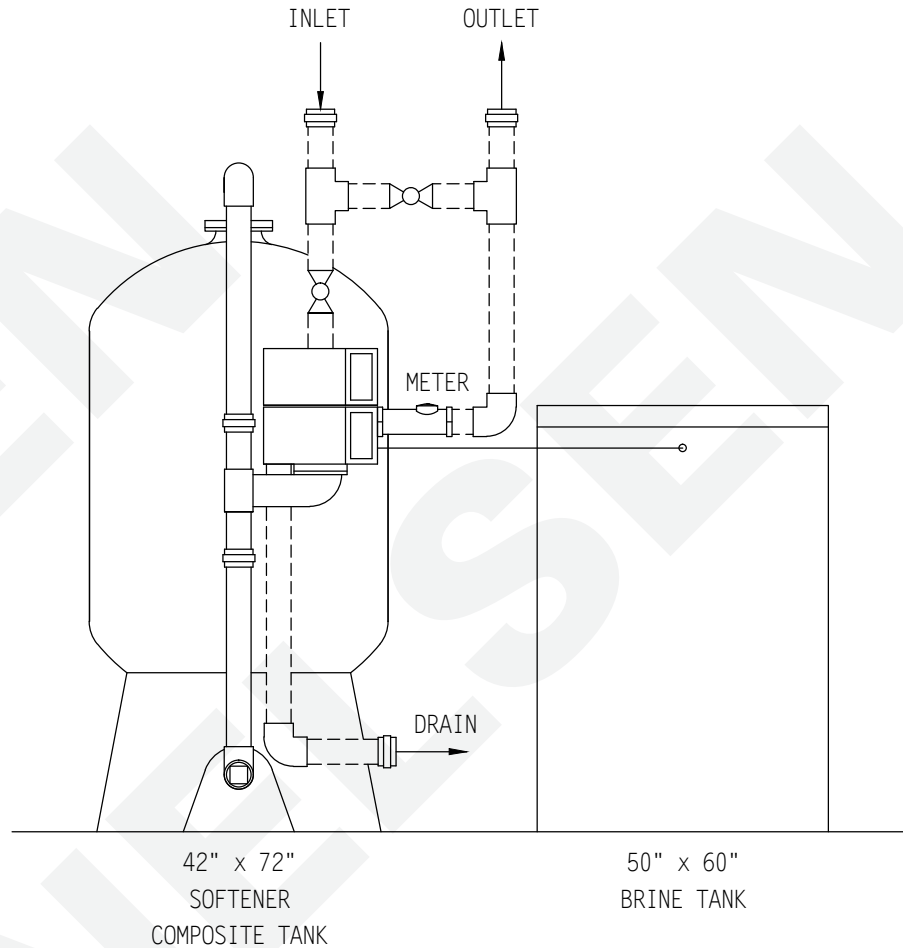

BRINE TANK

MODEL NO. BT5060R-494-5

TANK SIZE: 50" x 60"

POLYETHYLENE

CAPACITY:

500 gals.
 4500 lbs./salt

BRINE VALVE: 494

BRINE WELL: 5"

WEIGHT (APPROX)

TOTAL SHIPPING 3,450 lbs.

NOTE:

ALL DASHED PIPE, VALVES, AND FITTINGS NOT PROVIDED BY NELSEN CORPORATION.

SPACE REQUIRED (APPROX)

96"L x 52"W x 101"H

PEAK FLOWS ARE NOT RECOMMENDED FOR EXTENDED PERIODS OF TIME.

DO NOT SCALE DWG.

THIS DRAWING IS ISSUED IN CONFIDENCE AND CANNOT BE REPRODUCED OR USED TO MANUFACTURE ANYTHING SHOWN OR REFERRED TO WITHOUT DIRECT WRITTEN PERMISSION FROM NELSEN CORPORATION.

		NELSEN CORPORATION OHIO • ARIZONA • TEXAS • FLORIDA 5151 PORTSIDE DRIVE - MEDINA, OH 44256 800-362-9686 NELSENCORP.COM/COMMERCIAL	
		GENERAL ARRANGEMENT DWG. SOFTENER 900K COMPOSITE TANK SIMPLEX NXT2 SYSTEM	
DRAWN BY: RAR DATE: 01-30-17 CHECKED BY: PAGE 1 OF 1	REV:	DWG. NO. NCSMF-39/18NXT2-900-C5060	