

TRIPLEX NXT2 SOFTENER

MODEL NO. 29/17NXT2-TRI-150-C2450

CAPACITY: (each tank)

MIN. 120,000 grs. @ 10 lbs./cu.ft.

MAX. 150,000 grs. @ 15 lbs./cu.ft.

FLOW RATE: (each tank)

NORMAL 50 gpm.

PEAK 62 gpm.

BACKWASH 10 gpm

TANK SIZE: 18" x 65"

COMPOSITE

MEDIA: (each tank)

RESIN 5 cu.ft.

GRAVEL 100 lbs.

PIPE SIZE:

INLET 2"

OUTLET 2"

DRAIN 1"

BRINE 1/2"

METER 2"

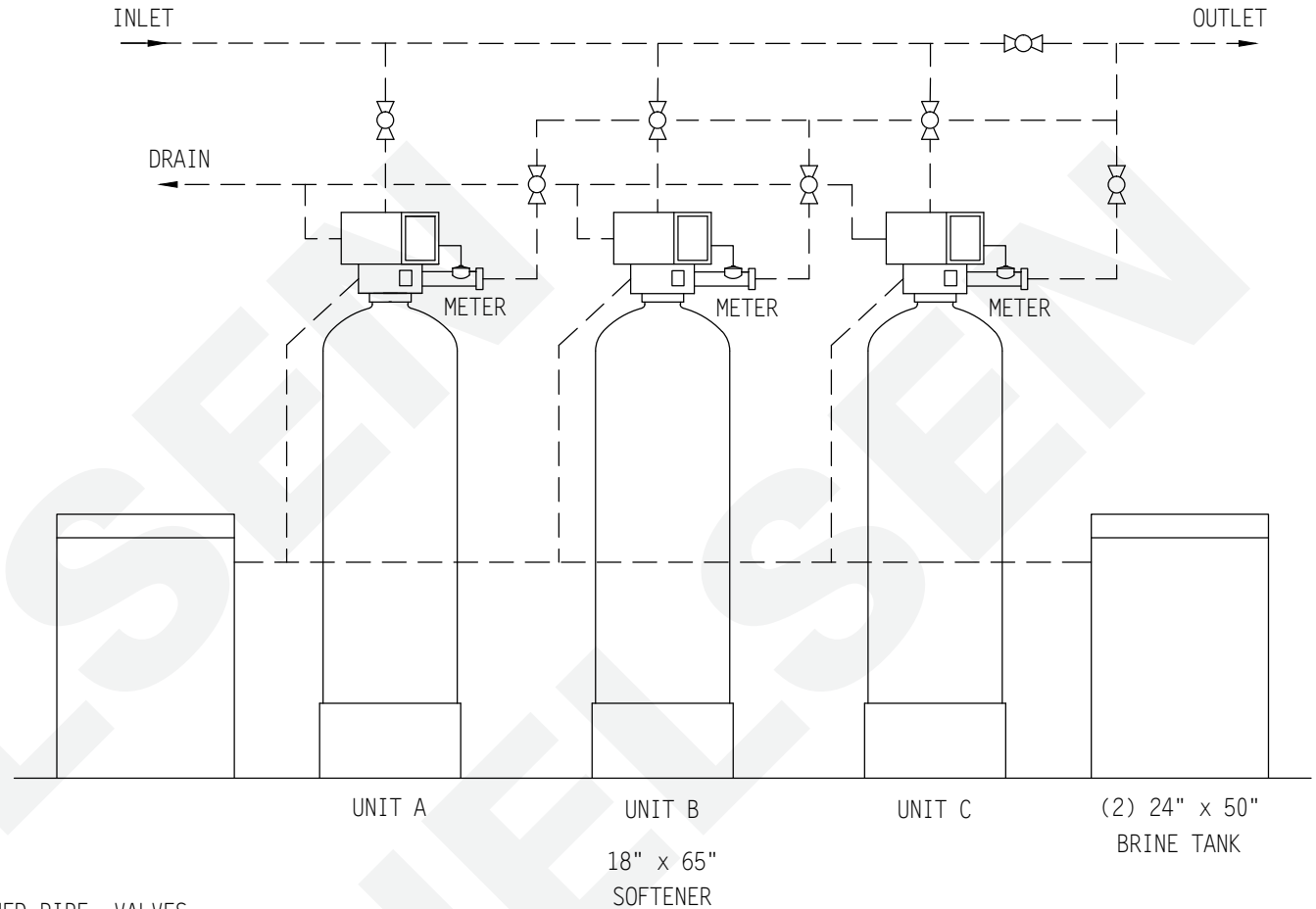

BRINE TANK

MODEL NO. BT2450R-454HF-5

TANK SIZE: 24" x 50"

POLYETHYLENE

CAPACITY: (each tank)

100 gals.

900 lbs./salt

BRINE VALVE: 454HF

BRINE WELL: 5"

WEIGHT (APPROX)

TOTAL SHIPPING 1,730 lbs.

NOTE:

ALL DASHED PIPE, VALVES, AND FITTINGS NOT PROVIDED BY NELSEN CORPORATION.

SPACE REQUIRED (APPROX)

118"L x 24"W x 79"H

PEAK FLOWS ARE NOT RECOMMENDED FOR EXTENDED PERIODS OF TIME.

DO NOT SCALE DRAWING

THIS DRAWING IS ISSUED IN CONFIDENCE AND CANNOT BE REPRODUCED OR USED TO MANUFACTURE ANYTHING SHOWN OR REFERRED TO WITHOUT DIRECT WRITTEN PERMISSION FROM NELSEN CORPORATION.

NELSEN
CORPORATION

NELSEN CORPORATION
OHIO • ARIZONA • TEXAS • FLORIDA
5151 Portside Drive, Medina, OH 44256
800-362-9686
NELSENCORP.COM/COMMERCIAL

GENERAL ARRANGEMENT DWG.
SOFTENER 150K COMPOSITE TANK
TRIPLEX NXT2 SYSTEM

DRAWN BY:	RAR
DATE:	03-06-17
CHECKED BY:	
PAGE 1 OF 1	REV:

DWG. NO.
29/17NXT2-TRI-150-C2450